



Document Number	PADI 008
Revision Number	1
Date	22 <sup>nd</sup> March 2018

## PALL Aerospace Vortex Systems Panel Assembly

### 1. Purpose and Scope

- 1.1 This document provides guidance on disposal and recycling of the component parts within Pall Vortex Systems (also known as Centrisep, Eaps and *PUREair*) on completion of the serviceable life.
- 1.2 This document, when read in conjunction with the relevant component maintenance manuals (CMM) for the unit, provides unit material guidance and disassembly procedures.
- 1.3 This document identifies and gives separate instructions for disposal of electrical or electronic components, motors and other components in accordance with applicable local legislation and regulatory requirements, including those of European Directive 2012/19/EU (related to waste electrical and electronic equipment).

### 2. Tools Required

Tools included in a standard aircraft maintenance tool kit plus those listed within the relevant CMM/AMM (Aircraft Maintenance Manual) will be necessary to accomplish this task.

### 3. Disassembly Method

- 3.1 Isolate and remove the Vortex Systems Panel Assembly from the aircraft in accordance with relevant AMM instructions.

This will include isolation of unit from bleed air supply, electrical connections, electrical bonding and mounting arrangements

- 3.2 Dis-assemble the Vortex Panel Assembly in accordance with “Disassembly” section of relevant CMM.

Ensure consideration is made to the materials or substances that the equipment may have been in contact with during use. The equipment must be decontaminated appropriately in accordance with local health and safety and environmental requirements to ensure safe handling during disassembly.

Comply with all of those requirements, plus the following requirements for safe work and any other requirements specific to the working location before dismantling this equipment, including:

- Observe all safety instructions and warnings.
- Comply with all safe handling and accident prevention measures.
- Ensure that no unauthorised person performs the disassembly and / or disposition operations.
- Wear appropriate personal protective equipment.

- 3.3 Dispose of components in accordance with the materials of construction and hazard classification of the contaminants present.



#### 4. Materials of Construction and Disposition Guidance: Vortex Panel Assembly

The assemblies shown and Figures 1, 2, 3 are illustrative examples only.

Vortex Panel Housing and Panels are shown as simple blocks, however the actual assembly may have a profile that will be more complex.

The equipment in your system will be a variant of the generic example(s) shown.

##### 4.1 Vortex panel Assembly – see Figure 1 and 2

- This shows a vortex panel housing (represented as a simple generic block) with assembled parts exploded to show typical locations.
- Table A provides a generic list of materials and disposition guidance for the Vortex panel components.

The filter will eject the contaminant using either:

- Ejector assembly comprising of a duct and ejector nozzles with manifold
- Scavenge fan\*\*

The FOD screen will be assembled either:

- Internally
- Externally
- You will need to review the “Description and Operation” section as contained in the relevant CMM for your product, to determine which optional equipment is included.

**Note:** Depending on the construction of the module, then; Not all of the listed parts may be removable, refer to the CMM for removable parts

\*\* WEEE may be applicable for these LRU's

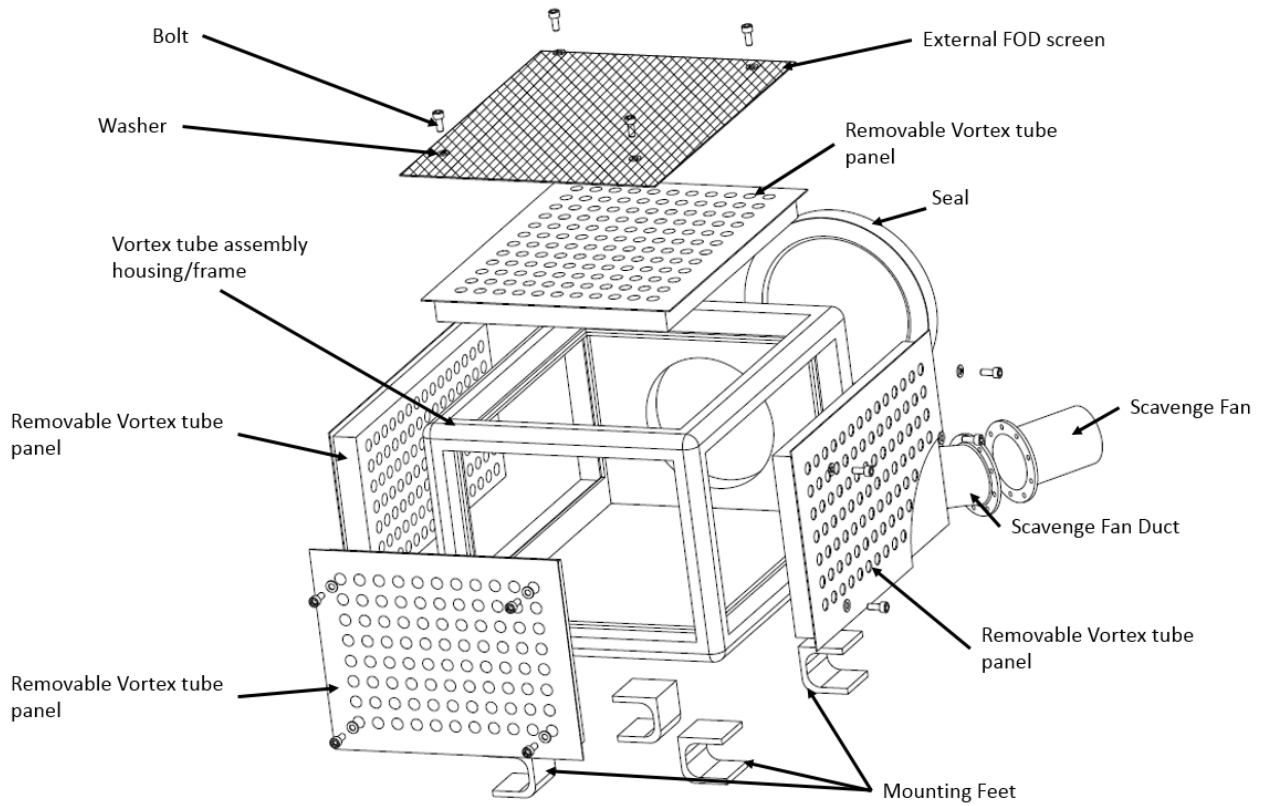

Exploded view of typical Vortex Systems Panel Assembly

Figure 1

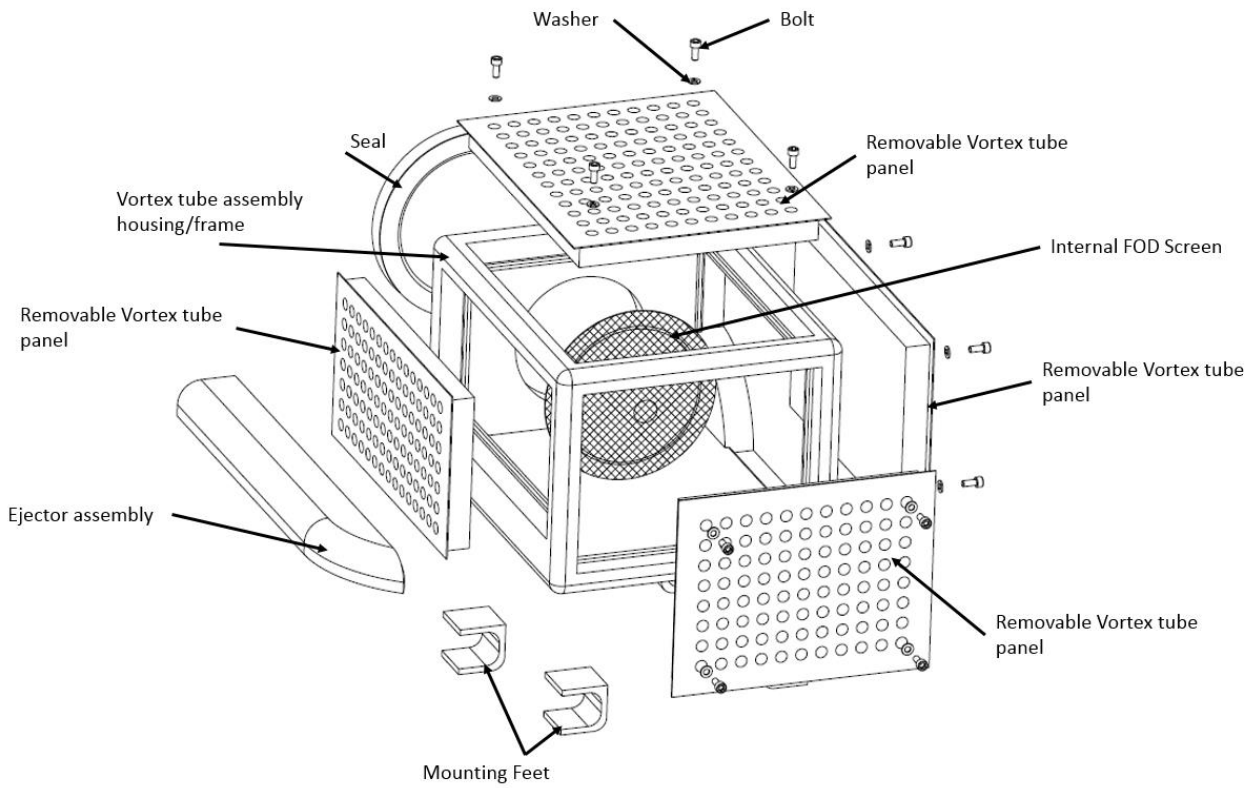

Exploded view of Alternative Vortex Systems Panel Assembly Components

Figure 2

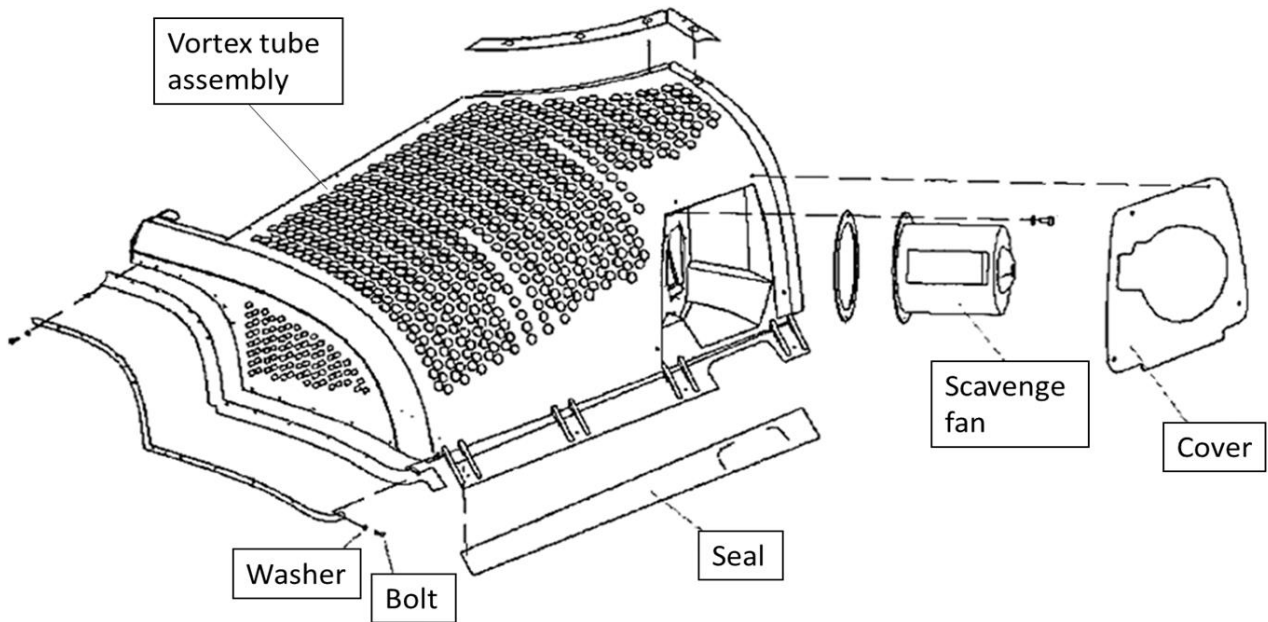

Exploded view of a second Alternative Vortex Systems Panel Assembly Components

Figure 3

<b>Vortex Systems Panel Assembly (Figure 1)</b>		
<b>Components</b>	<b>Material Type or Information (options that may be included)</b>	<b>Disposition Information</b>
Vortex Tube assembly housing	Anodised aluminium alloy, carbon fibre reinforced plastic, glass fibre reinforced plastic. (Some components may be bonded together with Epoxy resin, silicone sealant, chromate conversion compound). Graphene may be used as a bonding agent. Cyanoacrylate adhesive.	Metallic components can generally be recycled unless permanently contaminated.  Disposition should reflect the materials of construction and any contaminants present as the result of use. Dispose of in line with local and national legislation and guidelines.
Mounting Feet	Anodised aluminium alloy, Stainless Steel	Metallic components can generally be recycled unless permanently contaminated.  Disposition should reflect the materials of construction and any contaminants present as the result of use. Dispose of in line with local and national legislation and guidelines.
Removable vortex tube panel	Anodised aluminium alloy, Polypropylene, LDPE, silicone sealant, Epoxy resin, chromate conversion compound.	Disposition should reflect the materials of construction and any contaminants present as the result of use. Dispose of (as a single unit or separate components as far as possible) in line with local and national legislation and guidelines.
Scavenge fan duct	Carbon fibre reinforced plastic, glass fibre reinforced plastic, anodised aluminium alloy.	
Ejector assembly	Carbon fibre reinforced plastic, glass fibre reinforced plastic. Stainless steel, anodised aluminium alloy, copper (washer), ceramic (washer).	
Scavenge Fan		Dispose of as waste electrical or electronic equipment (WEEE)* see:  ·  after consideration and removal of any contaminants present as the result of use.
Seal	Silicone rubber	Dispose of in line with local and national legislation and guidelines for sealing materials.

<b>Vortex Systems Panel Assembly (Figure 1)</b>		
<b>Components</b>	<b>Material Type or Information (options that may be included)</b>	<b>Disposition Information</b>
External/Internal FOD screen	Anodised Aluminium alloy, Stainless Steel, Brisal ox, epoxy resin	Metallic components can generally be recycled unless permanently contaminated.  Disposition should reflect the materials of construction and any contaminants present as the result of use. Dispose of in line with local and national legislation and guidelines.
Bolt	Stainless Steel, Cadmium plated, passivated.	
Washer	Stainless Steel, Cadmium plated, passivated, Copper.	
<b>Note: Obtain copies of Material Safety Data Sheets to allow decision on disposal instructions as appropriate for review in accordance with local Environmental, Health and Safety procedures.</b>		

Note: Loctite is a registered trademark of Henkel

Materials of Construction and Disposition guidance for typical Filter Assembly

Table A